

## F - Type Plate Nuts (Screw type)

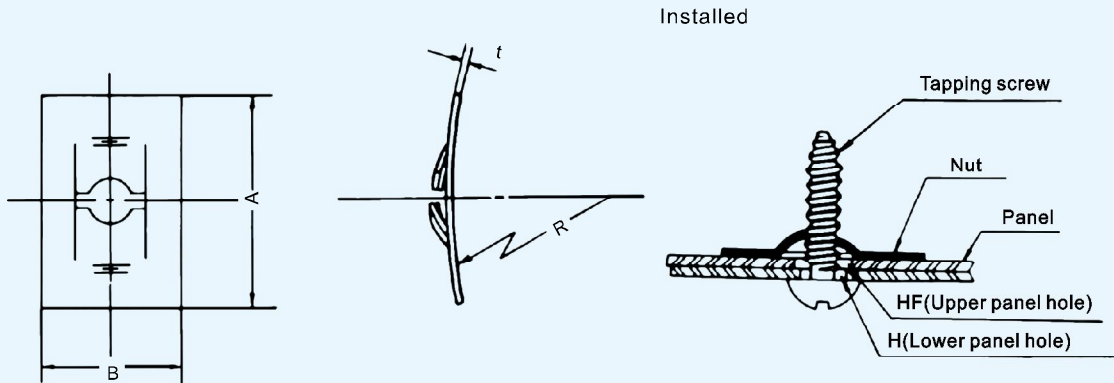

Unit:mm

Size-No.	applicable screw See note 1	Nut dimension				Panel size	
		A	B	R	t	H	HF
FSN-3001	M3×0.5	16	10	40	0.30	3.2	4
4001	M4×0.7	20	13	50	0.40	4.3	5
5001	M5×0.8	20	13	50	0.45	5.3	6
6001	M6×1.0	20	13	50	0.50	6.4	7

Material=Carbon spring steel. (Stainless spring steel.)  
Hardness=HRC 40~50  
Finish=Black phosphate coating (ACP). Zn plating

材質=高碳鋼、不銹鋼  
硬度=HRC 40~50  
表面處理=染黑、磷酸鹽

## J - Type Plate Nuts (Screw type)

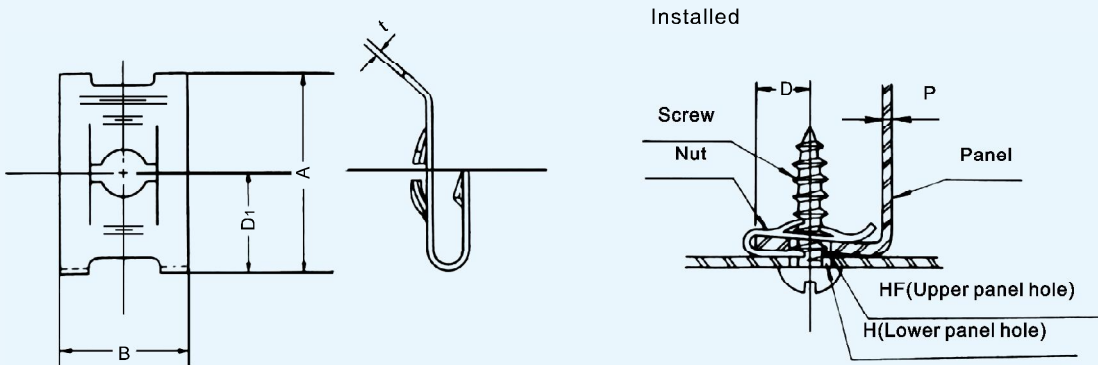

Unit:mm

Size-No.	Applicable screw See note 1	Nut dimension				Panel size				
		A	B	D1	t	P		D	H	HF
						Min.	Max.			
JSN-3001	M3×0.5	18.0	11.2	9.0	0.30	0.6	1.0	7.5	4.0	5.5
4001	M4×0.7	20.0	12.7	10.0	0.40	0.7	1.2	8.0	5.0	7.0
4003	M4×1.8	20.0	12.7	10.0	0.60	0.8	1.2	8.0	5.0	7.0
5001	M5×0.8	20.0	12.7	10.0	0.45	0.7	1.2	8.0	6.0	8.0
5004	M5×1.6	21.2	12.7	11.2	0.70	0.7	1.2	9.0	6.0	8.0
5003	M5×1.2	22.0	12.7	12.0	0.70	2.5	3.0	9.0	6.0	8.0
6001	M6×1.0	20.0	12.7	10.0	0.50	0.7	1.2	8.0	7.5	9.5
6002	M6×1.4	20.0	12.7	10.0	0.70	0.7	0.8	8.0	7.5	9.5

Material=Carbon spring steel. (Stainless spring steel.)  
Hardness=HRC 40~50  
Finish=Black phosphate coating (ACP). Zn plating

材質=碳鋼、不銹鋼  
硬度=HRC 40~50  
表面處理=染黑、磷酸鹽